

Power Transducer Series	
MULTI POWER MONITOR (4 digital displays)	MODEL 53U

MODEL & SUFFIX CODE SELECTION

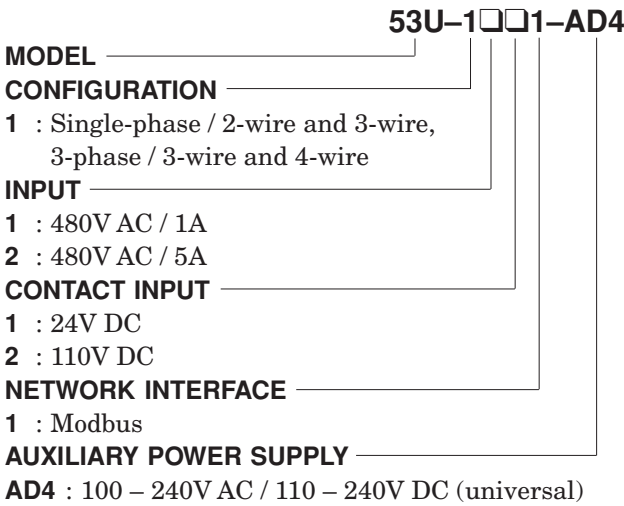

CE

Functions & Features

- Measures simultaneously several variables of a heavy-current power system: current, voltage, active, reactive and apparent power, active and reactive energy, power factor, frequency, etc.
- All measured values, counter values, display mode, setting data are stored in the non-volatile memory at the power off
- Conversion factors, system configuration, interval times are programmable using the front keys

Typical Applications

- Multi-functional power monitor incorporated in an electric device: saves space, wiring works, and cost

ORDERING INFORMATION

Specify code number. (e.g. 53U-1211-AD4)

RELATED PRODUCTS

- PC configurator software (model: 53UCFG)
Downloadable at M-System's web site:
<http://www.m-system.co.jp>
- PC configurator cable (model: MCN-CON)

GENERAL SPECIFICATIONS

Construction: 96-mm square (1/4 DIN size) panel flush mounted

Ingress protection

- Front panel:** Equivalent to IP 50
- Terminal block, housing:** Equivalent to IP 30

Connection

- Voltage input:** Connector type terminal block (applicable wire size ≤ 2.5 dia, $0.5 - 3.5$ mm²)
- Current input:** Screw terminal block (applicable wire size ≤ 2.4 dia, $0.5 - 3.5$ mm²)
- Output, power:** Connector type terminal block (applicable wire size ≤ 2.4 dia, $0.5 - 2.5$ mm²)

Configuration: Single phase/2-wire and 3-wire, 3-phase/3-wire balanced/unbalanced load, 3-phase/4-wire balanced/unbalanced load

Housing material: Flame-resistant resin (gray)

Isolation: Voltage input to current input to contact input to network interface or configurator jack to contact output to power

Measured variables

- Voltage:** 1 – N, 2 – N, 3 – N, 1 – 2, 2 – 3, 3 – 1
- Current:** 1, 2, 3, N
- Average current:** 1, 2, 3
- Active / reactive / apparent power:** 1, 2, 3, Σ
- Power factor:** 1, 2, 3, Σ
- Frequency**
- Active energy incoming / outgoing:** Σ
- Reactive energy inductive / capacitive:** Σ
- Apparent energy:** Σ
- Active / reactive / apparent power intervals (demand)**
- Other demands**
- Harmonic contents:** 2nd to 31st
- Max. and min. values**

■ **DISPLAY:** LCD with LED backlight (LED OFF timer available)
Signed: 4 digits, 3 lines
Energy: 9 digits, 1 line
Bargraph: 3 points

INPUT

Frequency: 50 / 60 Hz (45 – 65 Hz)

• **Voltage Input**

Rated voltage

Line-to-line (delta voltage): 480V

Line-neutral (phase voltage): 277V

Consumption VA: $\leq U_{LN}^2 / 300k\Omega$ / phase

Overload capacity: 200% of rating for 10 sec.,
120% continuous

Selectable primary voltage range: 50 – 400 000 V

• **Current Input**

Rated current: 1A or 5A

Consumption VA: $\leq I^2 \cdot 0.01\Omega$ / phase

Overload capacity: 4000% of rating for 1 sec., 2000%
for 4 sec., 120% continuous

Selectable primary current range: 1 – 20 000 A

Operational range

Voltage, current, apparent power: $\leq 120\%$ of the rating

Active/reactive power: $\leq \pm 120\%$ of the rating

Frequency: 45 – 65 Hz

Power factor: $\leq \pm 1$

■ **CONTACT INPUT:** 24V DC or 110V DC

(input resistance 6k Ω)

Contact detecting voltage: External 24V DC $\pm 10\%$
or 110V DC $\pm 10\%$

ON current: $\geq 1mA$ ($\leq 24k\Omega$ @24V, $\leq 110k\Omega$ @110V)

OFF current: $\leq 0.1mA$ ($\geq 240k\Omega$ @24V, $\geq 1.1M\Omega$ @110V)

Contact detecting time: 10 – 1000 msec.

Contact status can be monitored on the Modbus; usable to
reset energy count or to update average (demand) value

OUTPUT

■ **NETWORK INTERFACE**

Transmission: Half-duplex, asynchronous, no procedure

Interface: Conforms to EIA RS-485

Max. transmission distance: 500 meters

Baud rate: 1.2 – 38.4 kbps

Protocol: Modbus RTU

Media: Shielded twisted-pair cable (CPEV-S 0.9 dia.)

■ **OPEN COLLECTOR**

Programmable for either alarm or energy count.

Max. rated load: 130V DC @50mA

Continuous rated load: 130V DC @30mA

Saturation voltage: 1.5V DC

For maximum contact life and noise quenching with
inductive loads, external protection is recommended.

Measurands applicable to alarm: Voltage, current,
current intervals, neutral current,
frequency, energy, energy intervals
(ON delay, deadband and other parameters
are selectable)

Measurands applicable to count: Energy;
Pulse rate selectable within 0.1 – 10.000
kWh/p, kvarh/p, kVAh/p

Specifications subject to change without notice.

INSTALLATION

Auxiliary power supply

AC: Operational voltage range 85 – 264V;
47 – 66 Hz; $\leq 4VA$

DC: Operational voltage range 99 – 264V;
 $\leq 4W$; ripple 10% p-p max.

Operating temperature: -10 to +55°C (14 to 131°F)

Storage temperature: -20 to +80°C (-4 to +176°F)

Operating humidity: 90% RH max. (non-condensing)

Mounting: Panel flush mounting

Dimensions: W96×H108×D110 mm (3.78"×4.24"×4.33")

Weight: 300 g (0.66 lbs)

PERFORMANCE

Accuracy

Voltage: $\pm 0.3\%*$

Current: $\pm 0.3\%*$

Power: $\pm 0.5\%*$

Power factor: $\pm 0.5\%$

Frequency: $\pm 0.1\%*$

Energy: $\pm 1\%$

Harmonic contents: $\pm 1\%*$

Response time: ≤ 2 seconds (0 – 99%)

Insulation resistance: $\geq 100M\Omega$ with 500V DC

(voltage input to current input to contact
input to network interface or configurator
jack to contact output to power)

Dielectric strength: 4000V AC @1 minute

(voltage input or current input or contact
input or network interface or configurator
jack or contact output to power)
2500V AC @1 minute

(voltage input to current input to contact
input to contact output to network
interface or configurator jack)

*In percentage of the spans: 480V for voltage, 1A or 5A for
current, 7200W (5A) or 1440W (1A) for active power

STANDARDS & APPROVALS

CE conformity: EMC Directive (89/336/EEC)

EMI EN61000-6-4

EMS EN61000-6-2

Low Voltage Directive (73/23/EEC)

EN 61010-1

Installation category III

Pollution degree 2

FRONT & REAR VIEWS

FRONT VIEW

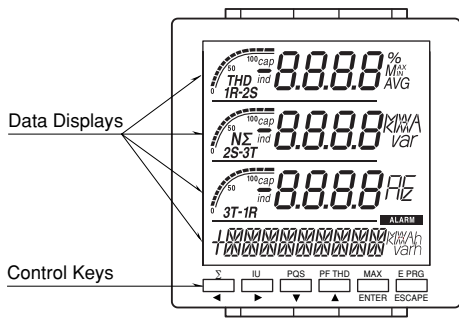

REAR VIEW

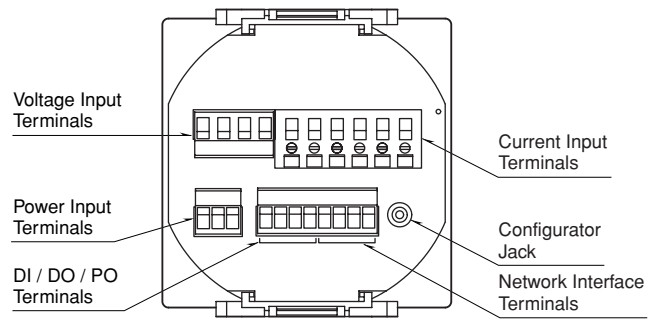

TERMINAL CONNECTIONS

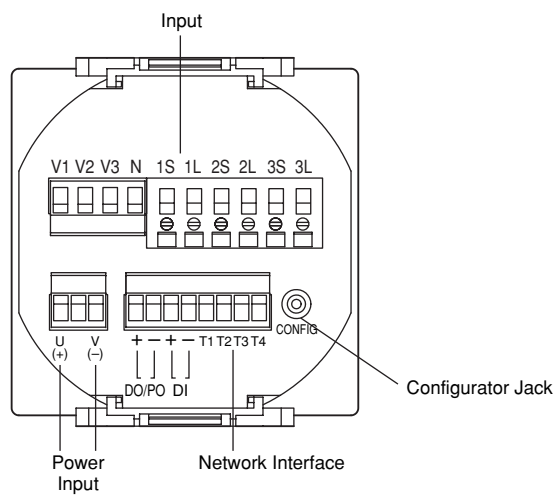

System / Application	Terminal	System / Application	Terminal
Single phase / 2-wire		Three phase / 4-wire, balanced load	
Three phase / 3-wire, balanced load		Three phase / 4-wire, unbalanced load	
Single phase / 3-wire		Three phase / 3-wire, unbalanced load	

No need of grounding for a low voltage circuit.

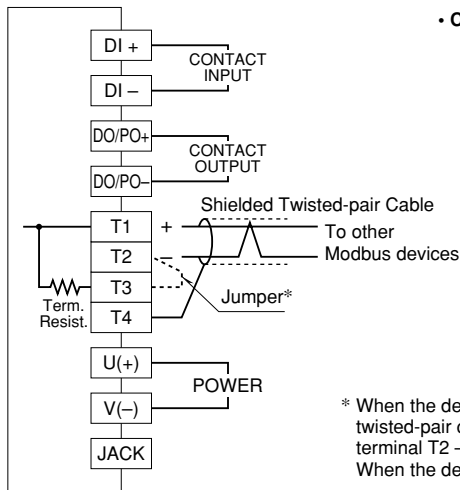

• Contact Input Connection Example

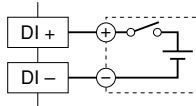

• Contact Output Connection Example

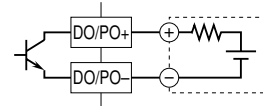

* When the device is located at the end of a transmission line via twisted-pair cable, (when there is no cross-wiring), close across the terminal T2 – T3 with the attached jumper pin (or with a leadwire). When the device is not at the end, remove the jumper pin.

MODBUS WIRING CONNECTION

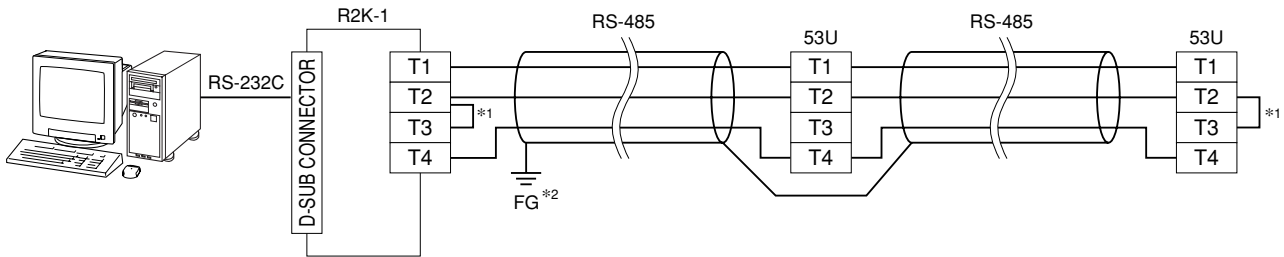

- *1. Internal terminating resistor is used when the device is at the end of a transmission line.
- *2. Install shield cables to all sections and ground them at single point.

EXTERNAL DIMENSIONS & TERMINAL ASSIGNMENTS mm (inch)

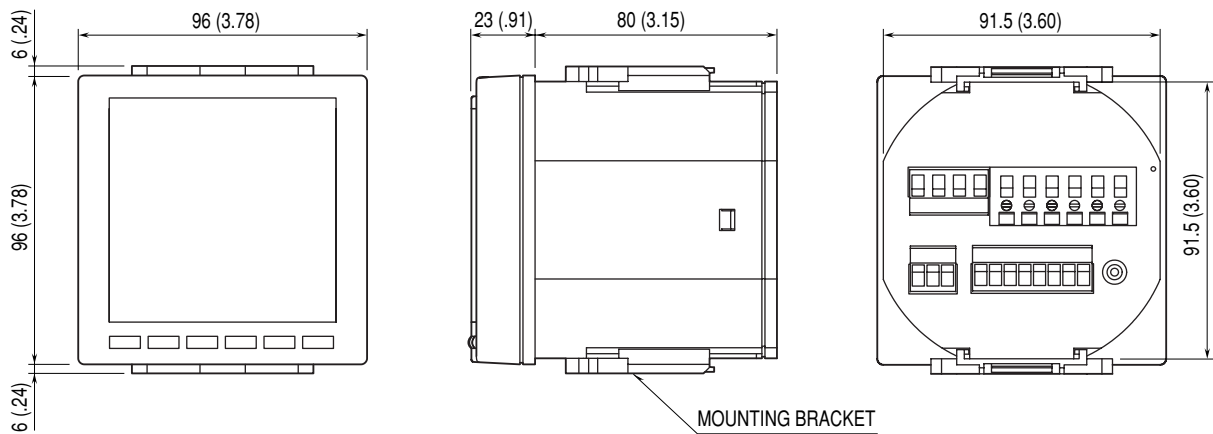

MOUNTING REQUIREMENTS mm (inch)

■ PANEL CUTOUT

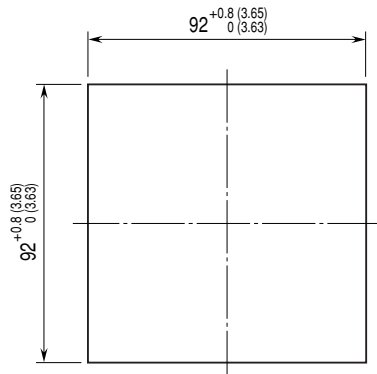

Panel thickness : 2 to 15 mm (0.08 to 0.59 inch)

SYSTEM CONFIGURATION EXAMPLE

