

MA15 Series

AC and DC power surge suppressor and filter



- 18kA surge protection and RFI filtering
- Protects panel loads up to 15 Amps in series, unlimited Amps in parallel
- Suitable for AC or DC application
- Thermal and short circuit protection
- LED status indication feature
- UL 1449 Recognized Component
- 10 year product warranty



The MA15 Series of surge protection devices protects electronic equipment and computer networks against the effects of 'noise pollution' induced in power supplies. MA15 units 'clean up' the effects of industrial noise and surges caused by lightning, switching devices, thyristor controls, transmission system overloads and power-factor correction circuits.

Industrial control systems utilizing programmable logic controllers (plc) and industrial computers are particularly vulnerable due to the aggressive electrical environments for which they are intended, such as process plants, factories and water treatment sites. Although industrial computers and plcs are designed to be rugged, the extra protection provided by the DIN rail mounting MA15 units is critical. Ideally suited for protecting panel mounted equipment and typically used in the controls section of a motor control centre (MCC), the MA15 range provides surge and RFI protected power.

With a unique 'three-stage' combination of

protection elements, these units suppress conducted RFI and voltage surges. The circuit elements are first, surge clipping components to absorb transient surges that may otherwise damage equipment, second a filter to suppress noise in the system and third, 'ring' suppression. The third of these prevents surges causing the filter to 'ring' (oscillate) under low load conditions – an effect that actually accentuates interference in most commercially available filters.

Suitable for AC or DC application, MA15 units reduce both electromagnetic emissions and the susceptibility of the associated equipment to emissions from other sources. MA15 devices also offer ultimate installation flexibility. To protect circuits rated 15A or less, MA15 devices should be installed in series. To protect higher current circuits, simply install the MA15 in parallel.

An LED status indication facility is standard with the MA15 units.

This displays both 'power on' and that protection is present. Thermal fusing is also incorporated into each 18kA rated device as an additional safety feature. MA15 units also offer short circuit protection for added peace of mind.

MA15 devices are UL 1449 Recognized Components (certified by UL for both US and Canadian requirements) and exceed the requirements of IEC 61000-4-5. As MA15 units suppress conducted RFI and voltage surges they enable associated equipment to comply with this aspect of European 'CE' mark standards.

AC and DC Power Protection

Specification

Maximum surge current

18kA (8/20 μ s) per mode

Maximum leakage current

<0.3mA

Maximum continuous operating current

15A series connection

Unlimited Amps in parallel

Working voltage

	AC	DC
MA15/D/1/SI	120V	140V
MA15/D/2/SI	240V	280V

Maximum continuous operating voltage

25% above nominal

Limiting voltage

@ 500A ring

120V/140V versions 295V

240V/280V versions 356V

@ 500A 8/20 μ s

120V/140V versions 320V

240V/280V versions 800V

@ 3kA 8/20 μ s

120V/140V versions 396V

240V/280V versions 975V

@ 10kA 8/20 μ s

120V/140V versions 585V

240V/280V versions 1210V

Maximum attenuation (typical)

-55dB @ 100MHz

Lines protected

L, N, G

Ambient temperature limits

-40°C to +85°C (working)

-40°F to +185°F (working)

Humidity

95% RH (non-condensing)

Casing

Polymide-PA, with G- or T-section (Top-hat) DIN-rail mounting foot

Connectors

Screw terminal

Terminals

0.1 inch² (2.5mm²)

12 AWG

Mounting

G- or T-section ('Top-hat') or 1.4 inch (35mm) DIN rail

Weight

3.53oz (100g)

Dimensions

See figure 1

EMC compliance

BS EN 60950 : 1992

BS EN 61000-6-2 : 1999

LED Indication

Green LED on Protection present

Green LED off Internal failure

Installation

Typical wiring connections for MA15 Series devices are indicated in figure 2. The grounding of the surge protector and the protected equipment is very important and, if possible, should be accomplished as illustrated.

Please note that the unit is marked Line and Load and it is important that the unit is installed with the Line side connected to the incoming power and the Load connected to the equipment to be protected. For parallel application however, the Line side is connected to the incoming power and the Load left unconnected.

MTL Incorporated

9 Merrill Industrial Drive, Hampton, NH 03842 USA

Tel: +1 800 835 7075, +1 603 926 0090 Fax: +1 603 926 1899

E-mail: info@mtlnh.com, WWW: www.mtlsurge.com

A member of the MTL Instruments Group plc

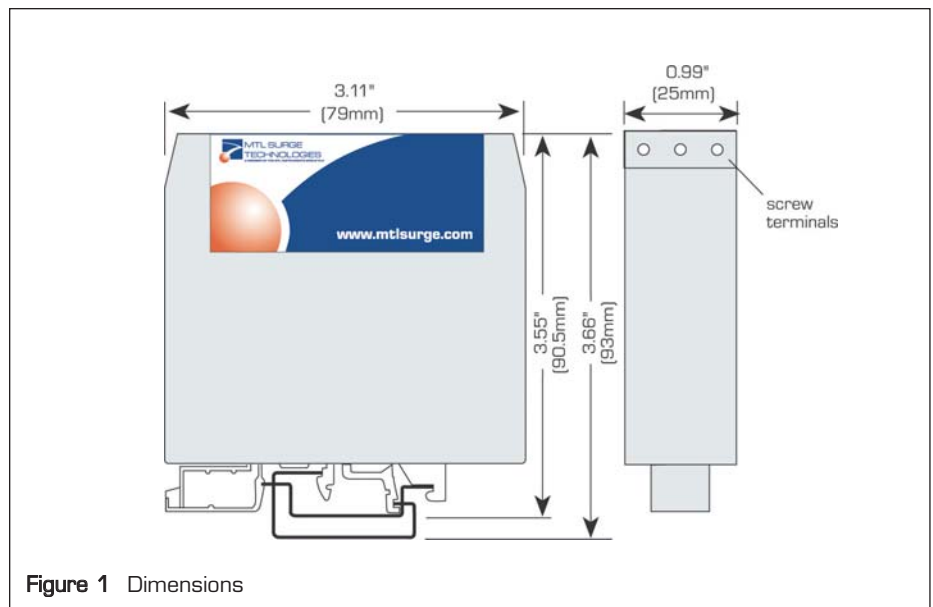

Figure 1 Dimensions

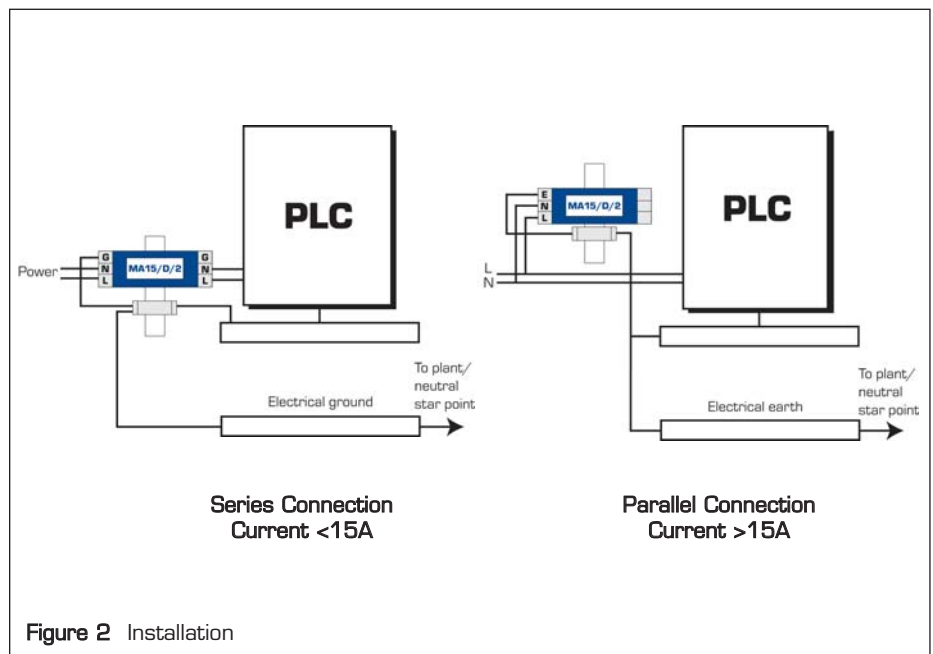

Figure 2 Installation

Approvals

Country	Standard/Authority	Approved for	Product
United States	UL 1449	AC Power Product	MA15/D/1/SI MA15/D/2/SI
Canada	Recognized Component		
United States	UL 1449	Hazardous Locations	MA15/D/1/SI MA15/D/2/SI
Canada	Recognized Component UL1604	Class I, Division 2 Groups A, B, C and D	

To order specify -

MA15/D/1/SI (120V/140V version with Status Indication)

MA15/D/2/SI (240V/280V version with Status Indication)

Note: In accordance with our policy of continuous improvement, we reserve the right to change the product's specification without notice.

